

# Jacuzzi J-585

## Specifications

<b>Seating Capacity</b> .....	6-7 Adults
<b>Dimensions</b> .....	91" x 91" x 37.5" Front/42" Side, (231.0 cm x 231.0 cm x 95.25 cm Front/107.0 cm Side); <b>For complete dimensions, See page 100</b>
<b>Dry Weight</b> .....	897 lbs (407 kg)
<b>Filled Weight (Spa Volume)</b> .....	5,403 lbs (2,451 kg)
<b>Filled Weight (Average Fill)</b> .....	4,569 lbs (2,072 kg)
<b>Water Capacity (Spa Volume)</b> .....	540 US gallons (2,044 Liters)
<b>Water Capacity (Average Fill)</b> .....	440 US gallons (1,666 Liters)
<b>Electronic Controls</b> .....	ProTouch™ Glass user interface. Touch-screen LCD displays temperature, time, cycles and jet control. Offers customizing of filtration cycles, CLEARRAY on demand, cleaning cycles and water temperature setting.
<b>Pump 1</b> .....	North America (60 Hz): 1-Speed, 5.1 HP break, 2.5 HP continuous, 56 Frame
<b>Export (50 Hz):</b> .....	<b>1-Speed, 2.0 HP continuous</b>
<b>Pump 2</b> .....	North America (60 Hz): 1-Speed, 5.1 HP break, 2.5 HP continuous, 56 Frame
<b>Export (50 Hz):</b> .....	<b>1-Speed, 2.0 HP continuous</b>
<b>Circulation Pump</b> .....	Yes, 8-Hour
<b>Total PowerPro® Jets</b> .....	46
<b>Seat A Jets</b> .....	4 PowerPro® FX Rotational, 3 PowerPro® FX Large Rotational
<b>Seat B Jets</b> .....	6 PowerPro® FX Rotational, 6 PowerPro® FX, 2 PowerPro® PX
<b>Seat C Jets</b> .....	2 PowerPro® RX, 2 PowerPro® FX
<b>Seat D Jets</b> .....	6 PowerPro® RX, 2 PowerPro® FX Directional
<b>Seat E Jets</b> .....	2 PowerPro® FX Large Rotational
<b>Seat F Jets</b> .....	3 PowerPro® MX
<b>Footwell (G)</b> .....	8 PowerPro® FX Small
<b>Massage Selectors</b> .....	2
<b>Air Controls</b> .....	4
<b>Water Management System</b> .....	One ProClarity® 40 ft <sup>2</sup> filter cartridge and 1 ProClarity® depth load filter on 8-hour circulation pump; one ProCatch® bag with ProClear® 60 ft <sup>2</sup> filter; Floating Weir; Factory installed CLEARRAY® Water Purification System
<b>Export (50 Hz):</b> .....	<b>Factory installed CLEARRAY® Water Purification System</b>
<b>LED Lighting</b> .....	Exterior corner lights, ProEdge™ interior lighting, two waterfall lights, one footwell light
<b>Synthetic Cabinet Colors</b> .....	Silverwood, Roasted Chestnut
<b>Acrylic Colors</b> .....	Platinum, Silver Pearl (Gypsum), Monaco, Midnight, Sahara, Porcelain
<b>Headrests</b> .....	4
<b>Waterfalls</b> .....	Two with independent flow rate (on or off) adjustment; powered by 8-hour circulation pump
<b>Electrical Requirements:</b> .....	North America (60 Hz): 240 VAC@40A, 50A, or 60A <b>Export (50 Hz): 230-240 VAC@2x16A or suitably rated circuit breaker to comply with local electrical codes. Certain countries may require dual power inputs; two GFCI RCD breakers are required for this configuration.</b>
<b>Warranty*</b> .....	North America (60 Hz): 10 Years Shell, 7 Years Shell Surface, 5 Years Plumbing Component Leaks, 5 Years Equipment and Controls, 5 Years Cabinet, 2 Years Jets, 2 Years Lights, 1 Year Stereo; <b>Export (50 Hz): 10 Years Shell, 7 Years Shell Surface, 5 Years Plumbing Component Leaks, 5 Years Equipment and Controls, 5 Years Cabinet, 2 Years Jets, 2 Years Lights, 2 Years Stereo</b>
<b>Special Features</b> .....	Factory installed SmartTub™ Module
<b>Audio System (Optional)</b> .....	BLUEWAVE® Wireless Spa Stereo System with Aux 3.5 mm jack port and Bluetooth capability; 4 single driver speakers and a powered subwoofer



\*(See Warranty Document for Specific Details)

Dimensions/Specifications are Subject to Change Without Notice

# Jacuzzi J-585

## Operation/Seat Depths

- Jets C are powered at all times when pump 1 is running

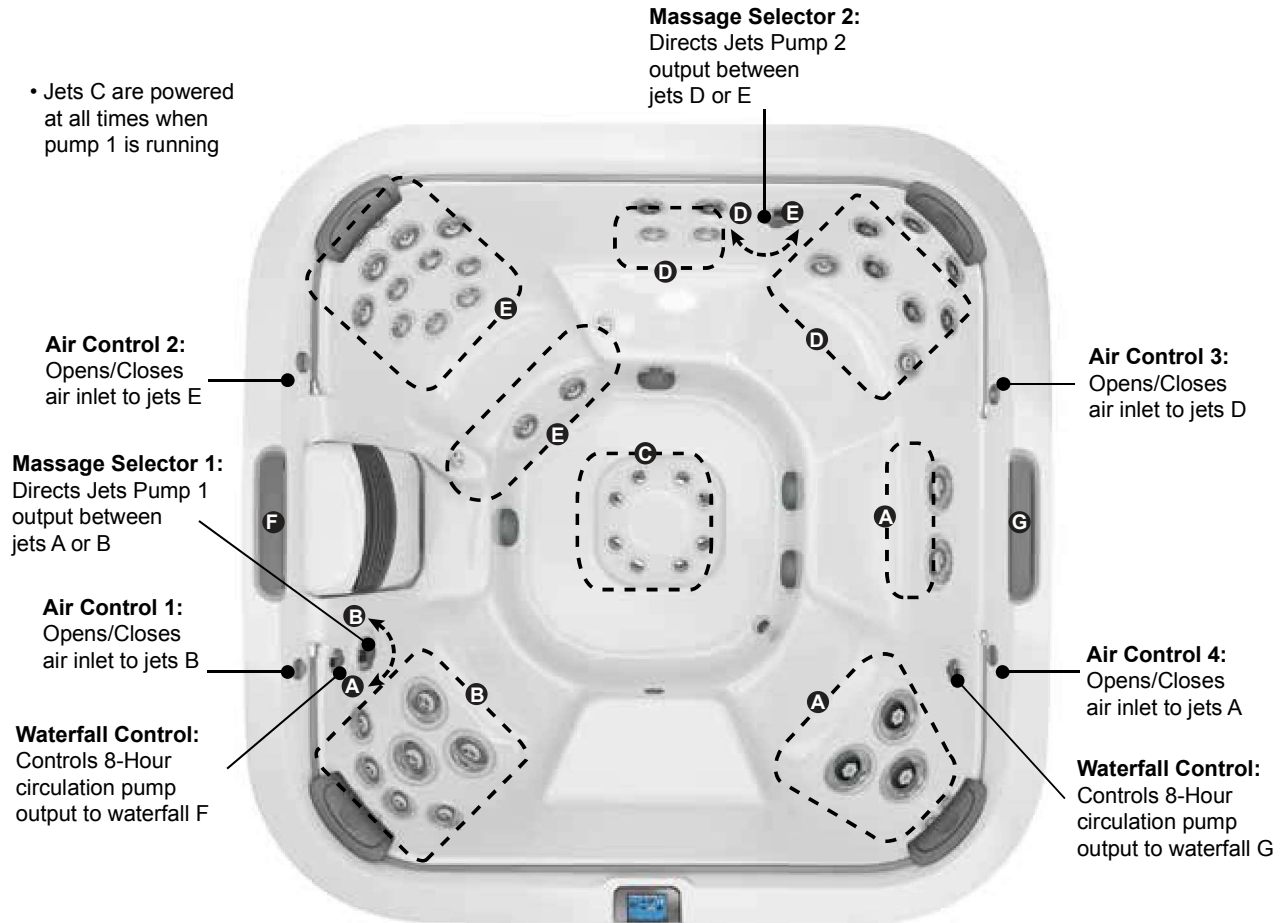

### 46 Total Jets



Spa Operation Subject to Change without Notice

## Seat Depths

- A = 26.63" (67.64 cm)**
- B = 21.00" (53.34 cm)**
- C = 27.00" (68.58 cm)**
- D = 20.00" (50.80 cm)**
- E = 23.00" (58.42 cm)**
- F = 21.38" (54.31 cm)**

- G = 24.50" (62.23 cm)**
- H = 20.13" (51.13 cm)**
- I = 33.00" (83.82 cm)**

Listed dimensions represent distance from top of acrylic to lowest point in seat. **Tolerance ± 0.5" (1.27 cm).**



Dimensions/Specifications are Subject to Change Without Notice

# Jacuzzi J-585

## Dimensions

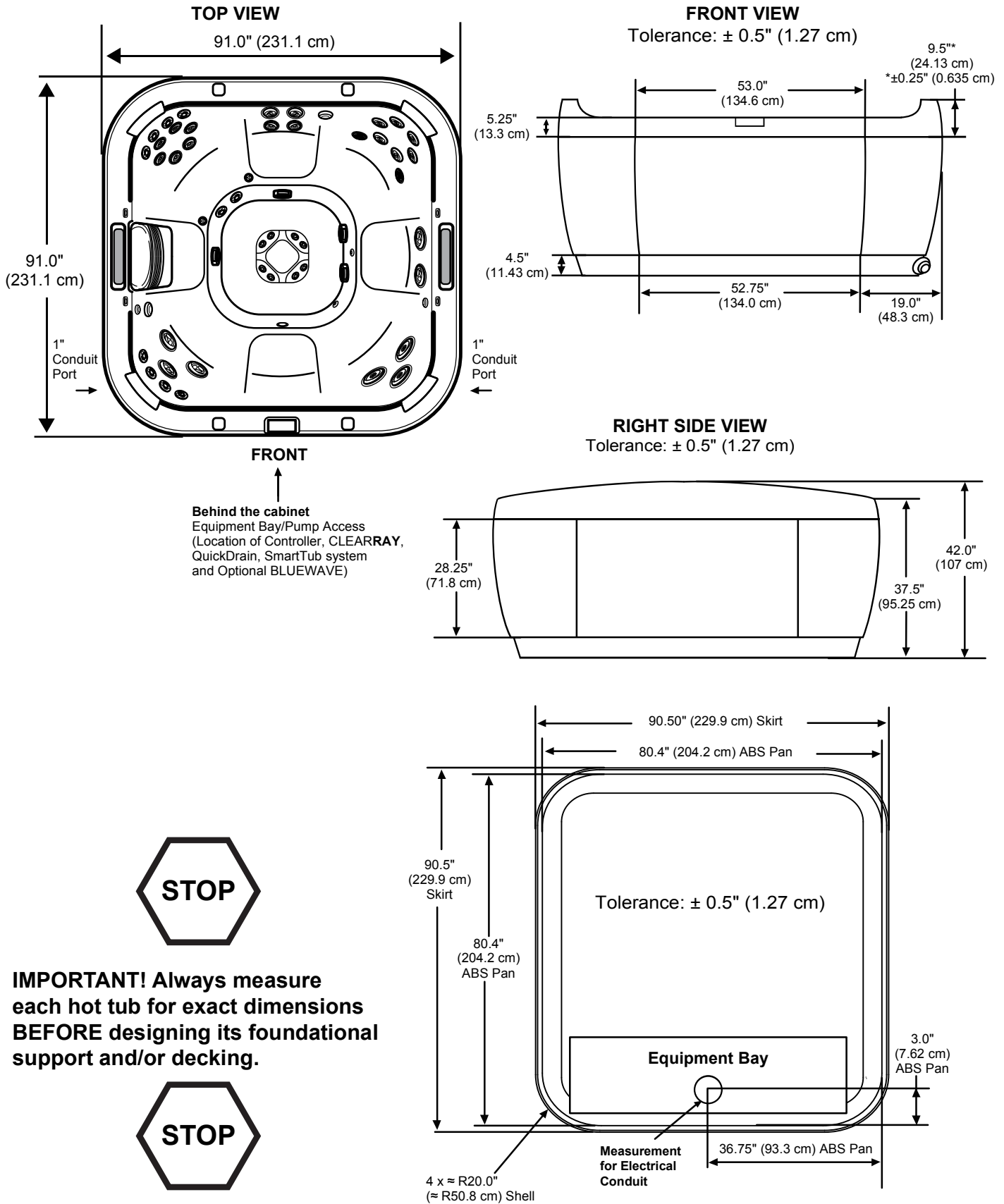

Dimensions/specifications subject to change without notice. Tolerance  $\pm 0.5"$  (1.27 cm)

# Jacuzzi J-575

## Specifications

<b>Seating Capacity</b> .....	5-6 Adults
<b>Dimensions</b> .....	91" x 91" x 37.5" Front/42" Side, (231.0 cm x 231.0 cm x 95.25 cm Front/107.0 cm Side); <b>For complete dimensions, See page 100</b>
<b>Dry Weight</b> .....	898 lbs (407 kg)
<b>Filled Weight (Spa Volume)</b> .....	5,446 lbs (2,470 kg)
<b>Filled Weight (Average Fill)</b> .....	4,612 lbs (2,092 kg)
<b>Water Capacity (Spa Volume)</b> .....	545 US gallons (2,063 Liters)
<b>Water Capacity (Average Fill)</b> .....	445 US gallons (1,685 Liters)
<b>Electronic Controls</b> .....	ProTouch™ Glass user interface. Touch-screen LCD displays temperature, time, cycles and jet control. Offers customizing of filtration cycles, CLEARRAY® on demand, cleaning cycles and water temperature setting.
<b>Pump 1</b> .....	North America (60 Hz): 1-Speed, 5.1 HP break, 2.5 HP continuous, 56 Frame
<b>Export (50 Hz):</b> .....	<b>1-Speed, 2.0 HP continuous</b>
<b>Pump 2</b> .....	North America (60 Hz): 1-Speed, 5.1 HP break, 2.5 HP continuous, 56 Frame
<b>Export (50 Hz):</b> .....	<b>1-Speed, 2.0 HP continuous</b>
<b>Circulation Pump</b> .....	Yes, 8-Hour
<b>Total PowerPro® Jets</b> .....	49
<b>Seat A Jets</b> .....	6 PowerPro® FX Rotational, 6 PowerPro® FX
<b>Seat B Jets</b> .....	6 PowerPro® FX Rotational, 2 PowerPro® FX Large Rotational
<b>Seat C Jets</b> .....	6 PowerPro® RX, 2 PowerPro® FX directional, 8 PowerPro® PX, 2 PowerPro® FX Large Rotational
<b>Seat D Jets</b> .....	2 PowerPro® FX Large Rotational
<b>Seat E Jets</b> .....	3 PowerPro® MX, 2 PowerPro® NX2, 2 PowerPro® FX Rotational
<b>Footwell (F)</b> .....	2 PowerPro® MX
<b>Massage Selectors</b> .....	2
<b>Air Controls</b> .....	4
<b>Water Management System</b> .....	One ProClarity® 40 ft <sup>2</sup> filter cartridge and 1 ProClarity® depth load filter on 8-hour circulation pump; one ProCatch® bag with ProClear® 60 ft <sup>2</sup> filter; Floating Weir; Factory installed CLEARRAY® Water Purification System
<b>Export (50 Hz):</b> .....	<b>Factory installed CLEARRAY® Water Purification System</b>
<b>LED Lighting</b> .....	Exterior corners lights, ProEdge™ interior lighting, two waterfall lights, one footwell light
<b>Synthetic Cabinet Colors</b> .....	Silverwood, Roasted Chestnut
<b>Acrylic Colors</b> .....	Platinum, Silver Pearl (Gypsum), Monaco, Midnight, Sahara, Porcelain
<b>Headrests</b> .....	4
<b>Waterfalls</b> .....	Two with independent flow rate (on or off) adjustment; powered by 8-hour circulation pump
<b>Electrical Requirements:</b> .....	North America (60 Hz): 240 VAC@40A, 50A, or 60A
	<b>Export (50 Hz): 230-240 VAC@2x16A or suitably rated circuit breaker to comply with local electrical codes. Certain countries may require dual power inputs; two GFCI RCD breakers are required for this configuration.</b>
<b>Warranty*</b> .....	North America (60 Hz): 10 Years Shell, 7 Years Shell Surface, 5 Years Plumbing Component Leaks, 5 Years Equipment and Controls, 5 Years Cabinet, 2 Years Jets, 2 Years Lights, 1 Year Stereo;
	<b>Export (50 Hz): 10 Years Shell, 7 Years Shell Surface, 5 Years Plumbing Component Leaks, 5 Years Equipment and Controls, 5 Years Cabinet, 2 Years Jets, 2 Years Lights, 2 Years Stereo</b>
<b>Special Features</b> .....	Factory installed SmartTub™ Module
<b>Audio System (Optional)</b> .....	BLUEWAVE® Wireless Spa Stereo System with Aux 3.5 mm jack port and Bluetooth capability; 4 single driver speakers and a powered subwoofer

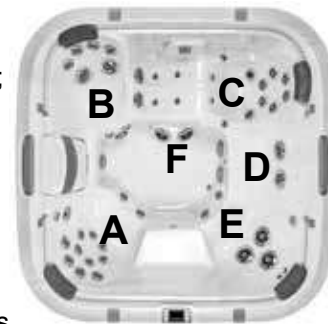

\*(See Warranty Document for Specific Details)

Dimensions/Specifications are Subject to Change Without Notice

# Jacuzzi J-575

## Operation/Seat Depths

- Jets C are powered at all times when pump 1 is running

**Massage Selector 2:**  
Directs Jets Pump 2 output between jets D or E

**Air Control 2:**  
Opens/Closes air inlet to jets D

**Air Control 3:**  
Opens/Closes air inlet to jets E

**Massage Selector 1:**  
Directs Jets Pump 1 output between jets A or B

**Air Control 1:**  
Opens/Closes air inlet to jets B

**Air Control 4:**  
Opens/Closes air inlet to jets A and C

**Waterfall Control:**  
Controls 8-Hour circulation pump output to waterfall F

**Waterfall Control:**  
Controls 8-Hour circulation pump output to waterfall G

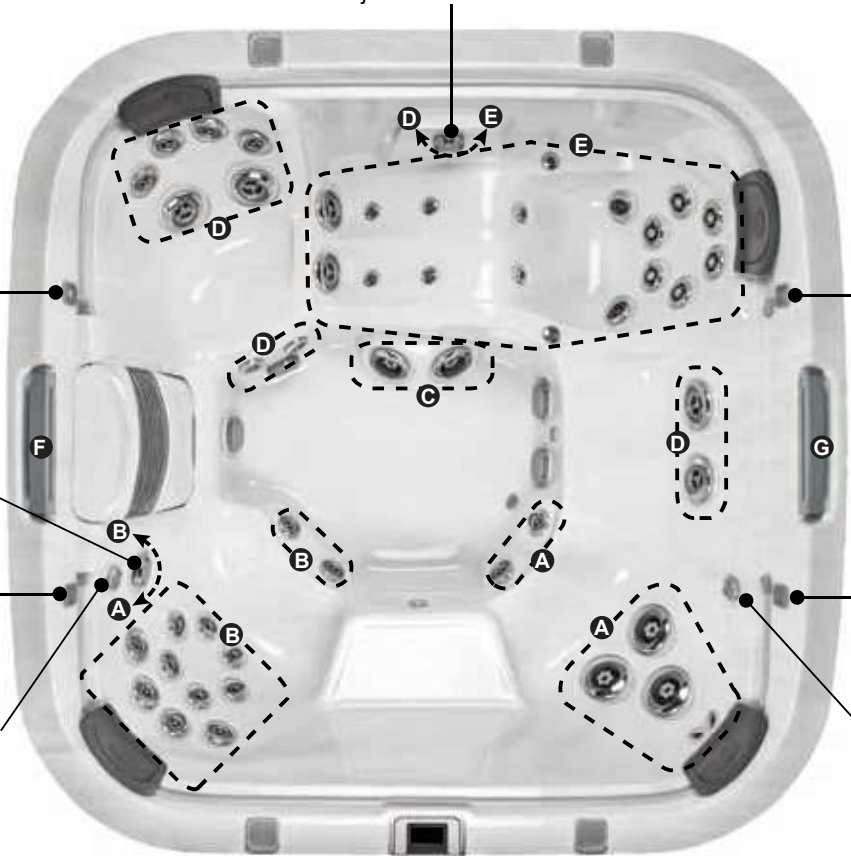

### 49 Total Jets



Spa Operation Subject to Change without Notice

## Seat Depths

- A = 27.50" (69.85 cm)
- B = 23.50" (59.69 cm)
- C = 27.00" (68.58 cm)
- D = 21.50" (54.61 cm)
- E = 24.75" (62.87 cm)
- F = 18.25" (46.36 cm)

- G = 33.25" (84.46 cm)
- C1 = 17.75" (45.09 cm)
- C2 = 24.75" (62.87 cm)

Listed dimensions represent distance from top of acrylic to lowest point in seat. Tolerance  $\pm 0.5"$  (1.27 cm).

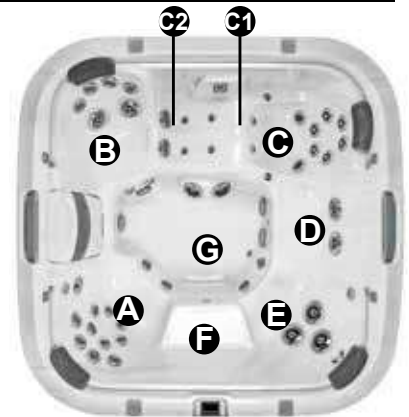

Dimensions/Specifications are Subject to Change Without Notice

# Jacuzzi J-575

## Dimensions

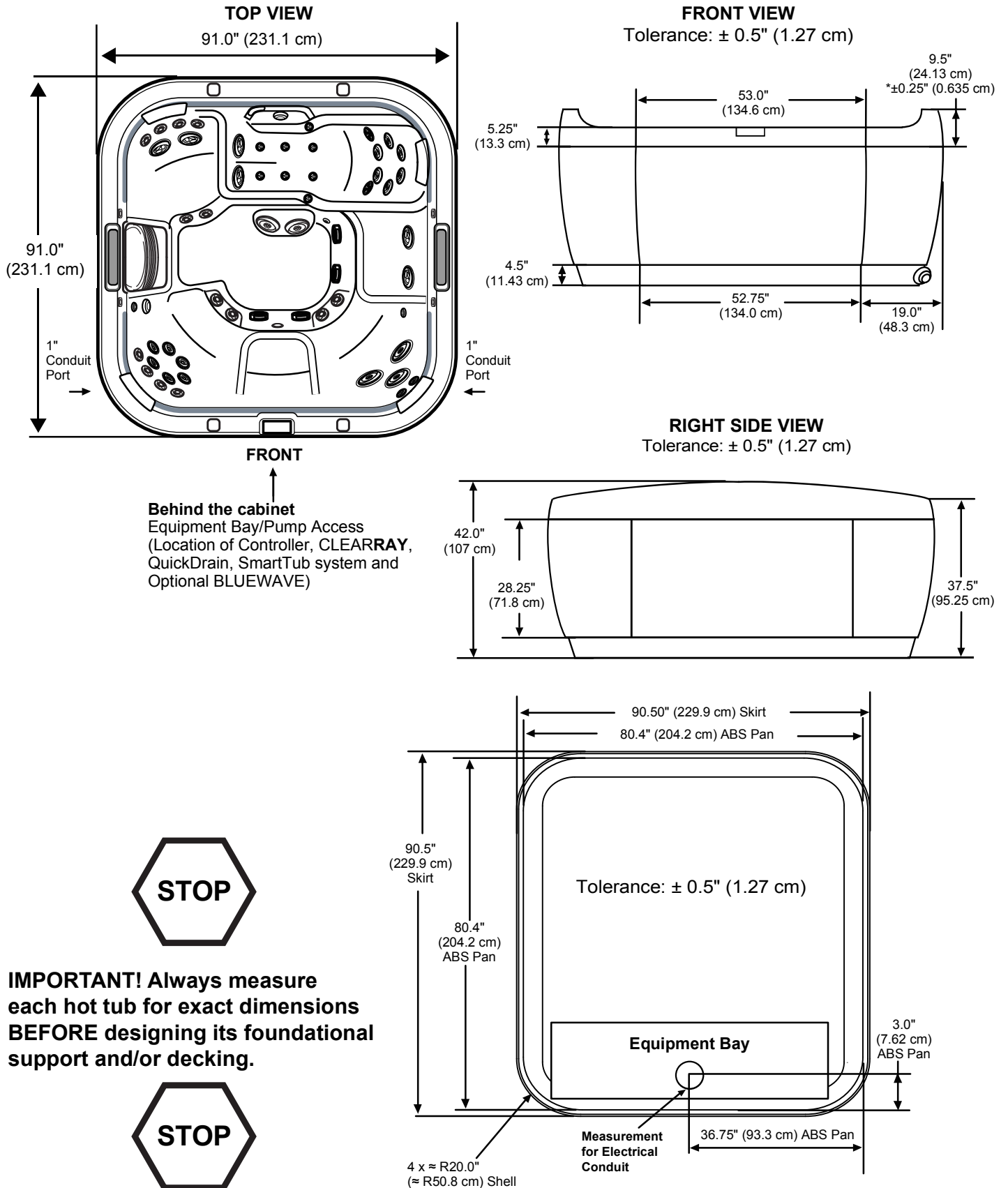

**IMPORTANT! Always measure each hot tub for exact dimensions BEFORE designing its foundational support and/or decking.**

Dimensions/specifications subject to change without notice. Tolerance  $\pm 0.5"$  (1.27 cm)