

Soul 30™ Jets

Specifications

Seating Capacity	6 Adults
Dimensions	78" x 78" x 36" (198 cm x 198 cm x 91 cm);
Filled Weight (Spa Volume)	3,864 lbs (1,753 kg)
Filled Weight (Average Fill)	2,971 lbs (1,348 kg)
Water Capacity (Spa Volume) ...	417 US gallons (1,579 Liters)
Water Capacity (Average Fill) ...	310 US gallons (1,173 Liters)
Electronic Controls	Digital Touch Controller. Offers customizing of cleaning cycles and water temperature setting.
Pump 1	North America (60 Hz): 2-Speed, 3.0 HPR continuous
Export (50 Hz):	2 kW, 2-Speed
Pump 2	N/A
Export (50 Hz):	N/A
Circulation Pump	N/A
Total Jets	30
Seat A Jets	6 DirectionalMax1, 6 DirectionalMax2
Seat B Jets	1 DirectionalMax1
Seat C Jets	6 DirectionalMax2
Seat D Jets	2 DirectionalMax1
Seat E Jets	4 DirectionalMax1, 2 DirectionalMax2
Seat F Jets	1 DirectionalMax1
Footwell (G)	2 DirectionalMax1
Massage Selectors	N/A
Air Controls	2
Water Management System	One Easy Kleen 30 ft ² filter cartridge; Optional factory installed Ozone
Export (50 Hz):	Optional factory installed Ozone
LED Lighting	Multicolor Waterfall light; Footwell light, Exterior corner lights (8 qty)
Shell/Cabinet Colors	Mystic Sparkle, Tuscan Sparkle, Night Sparkle, Glacier Sparkle
Headrests	3
Waterfalls	One with independent flow rate (on or off) adjustment; powered by pump 1
Heater:	Hi Flow 1.0kW/4kW
Export (50 Hz):	Hi Flow 3.0kW
Electrical Requirements:	North America (60 Hz): Convertible 120 VAC@15A or 240 VAC@30A, 40A
	Export (50 Hz): 230-240V@1x16A, 1X32A
Warranty*	North America (60 Hz): 5 Years Shell, 5 Years Shell Surface, 1 Year Plumbing Component Leaks, 1 Year Equipment and Controls, 1 Year Cabinet, 1 Year Jets, 1 Year Lights;
	Export (50 Hz): 5 Years Shell, 5 Years Shell Surface, 2 Years Plumbing Component Leaks, 2 Years Equipment and Controls, 2 Years Cabinet, 2 Years Jets, 2 Years Lights;
Special Features	Optional Suite Package Add-On



*(See Warranty Document for Specific Details)

Dimensions/Specifications are Subject to Change Without Notice

Soul 30 Jets

Operation/Seat Depths

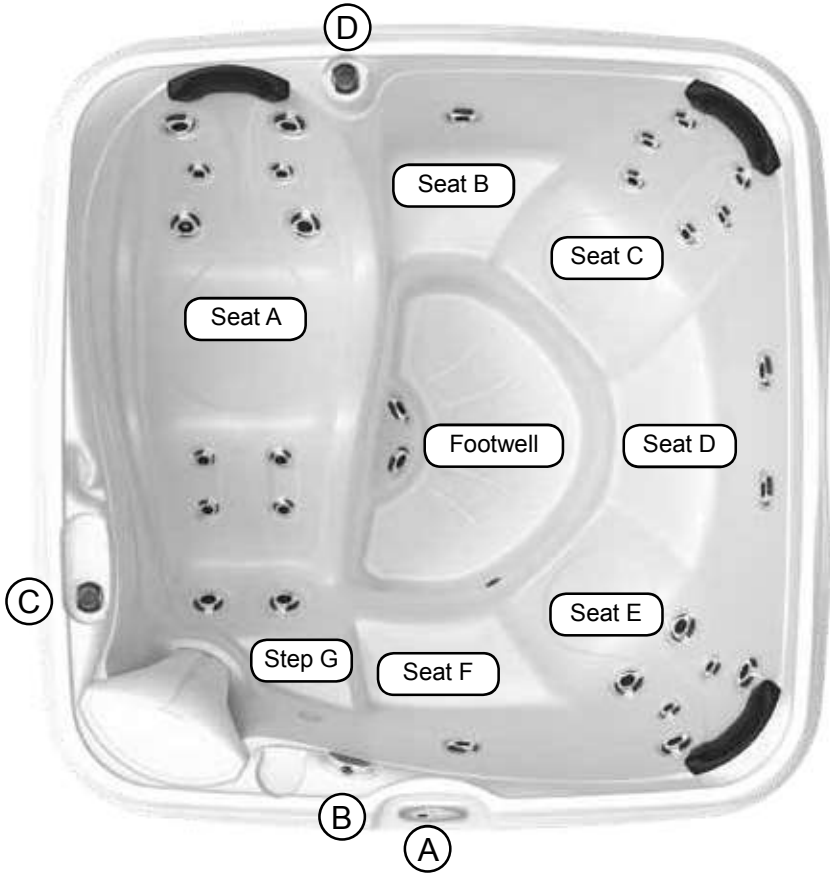

- (A) Topside Control - Activate Jet Pump, Light and Control Water Temperature
 - (B) Water Feature Control - Controls Water Feature Output.
 - (C) Air Control - Activates Seat A Jets (6 DirectionalMax1 Jets, 6 DirectionalMax2 Jets)
 - (D) Air Control - Activates Seat B Jets (1 DirectionalMax1 Jet), Seat C Jets (6 DirectionalMax2 Jets), Seat D Jets (2 DirectionalMax1 Jets), Seat E Jets (4 DirectionalMax1 Jets, 2 DirectionalMax2 Jets), Seat F Jets (1 DirectionalMax1 Jet), Footwell Jets (2 DirectionalMax1 Jets)
- Jet Pump 1: All seats and footwell jets

30 Total Jets

DirectionalMax1
Jets (16)

DirectionalMax2
Jets (14)



Spa Operation Subject to Change without Notice

- A = 25.75" (65.40 cm)
- B = 24.50" (62.23 cm)
- C = 28.00" (71.12 cm)
- D = 24.75" (62.86 cm)
- E = 26.50" (67.30 cm)
- F = 23.25" (59.06 cm)
- G = 19.00" (48.26 cm)
- H = 34.50" (87.63 cm)

Seat Depths

Listed dimensions represent distance from top of spa to lowest point in seat.
Tolerance: ± 0.5" (1.27 cm)



Dimensions/Specifications are Subject to Change Without Notice

Soul 30 Jets

Dimensions

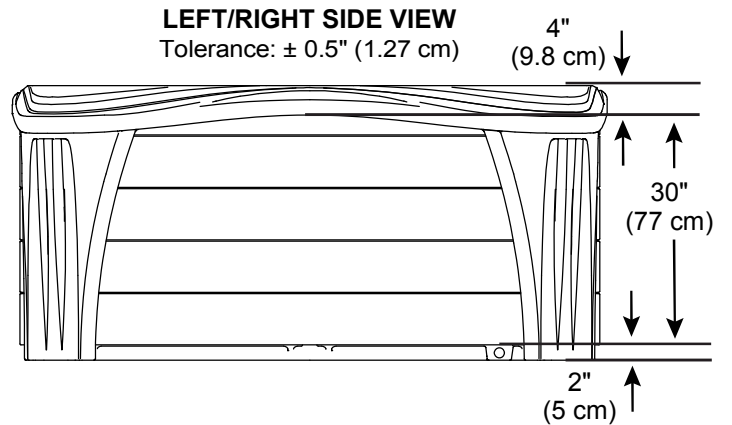
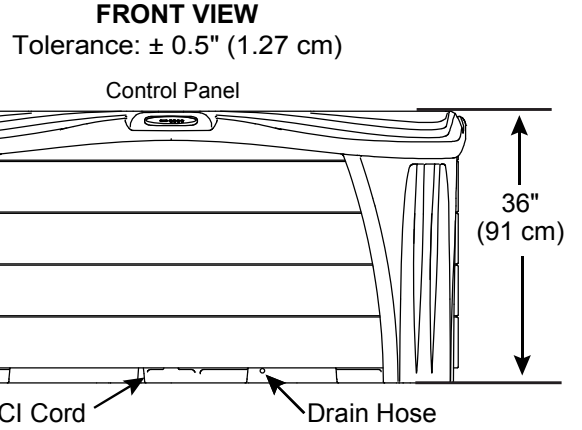
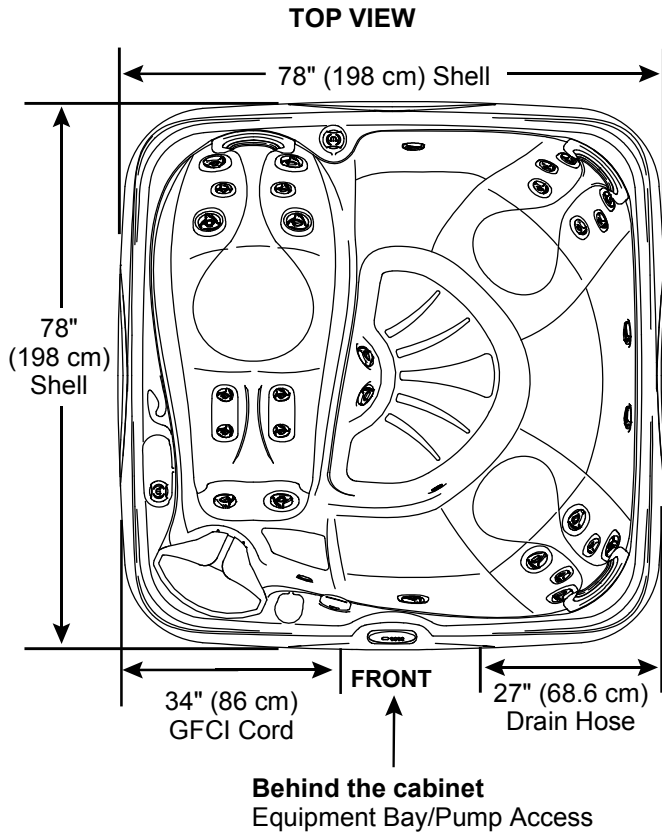

IMPORTANT! Always measure each hot tub for exact dimensions BEFORE designing its foundational support and/or decking.

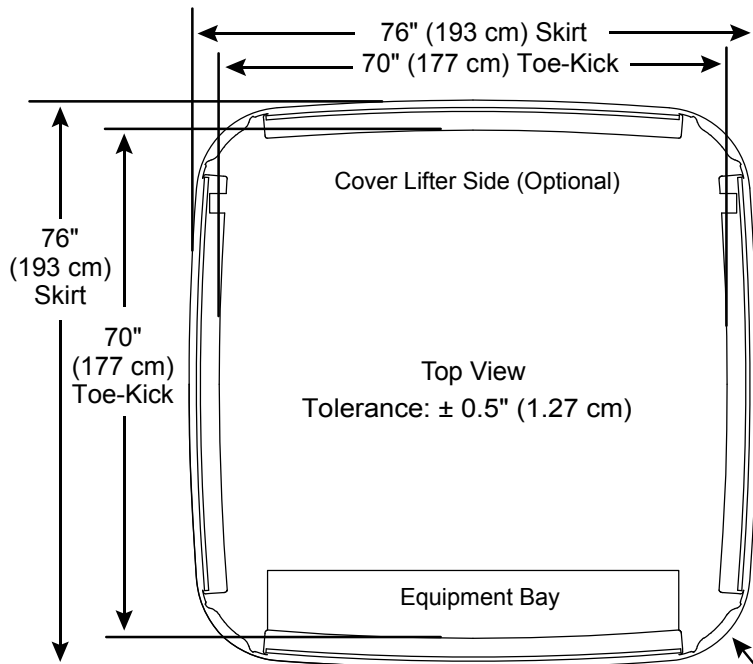

4 x $\approx R12.0"$
($\approx R30.5$ cm) Shell

Dimensions/specifications subject to change without notice. Tolerance $\pm 0.5"$ (1.27 cm)

Echo 30™ Jets

Specifications

Seating Capacity	7 Adults	
Dimensions	78" x 78" x 36" (198 cm x 198 cm x 91 cm);	
Dry Weight	414 lbs (187 kg)	
Filled Weight (Spa Volume)	4,117 lbs (1,867 kg)	
Filled Weight (Average Fill)	3,150 lbs (1,429 kg)	
Water Capacity (Spa Volume) ...	444 US gallons (1,681 Liters)	
Water Capacity (Average Fill) ...	328 US gallons (1,242 Liters)	
Electronic Controls	Digital Touch Controller. Offers customizing of cleaning cycles and water temperature setting.	
Pump 1	North America (60 Hz): 2-Speed, 3.0 HP continuous	
Export (50 Hz):	2 kW, 2-Speed	
Pump 2	N/A	
Export (50 Hz):	N/A	
Circulation Pump	N/A	
Total Jets	30	
Seat A Jets	4 DirectionalMax1 Jets, 2 DirectionalMax2 Jets	
Seat B Jets	2 DirectionalMax1 Jets	
Seat C Jets	8 DirectionalMax2 Jets	
Seat D Jets	6 DirectionalMax2 Jets	
Seat E Jets	2 DirectionalMax1 Jets	
Seat F Jets	4 DirectionalMax1 Jets, 2 DirectionalMax2 Jets	
Massage Selectors	N/A	
Air Controls	2	
Water Management System	One Easy Kleen 30 ft ² filter cartridge; Optional factory installed Ozone	
Export (50 Hz):	Optional factory installed Ozone	
LED Lighting	Multicolor waterfall light; Exterior corner light (white color only)	
Shell/Cabinet Colors	Mystic Sparkle, Tuscan Sparkle, Night Sparkle, Glacier Sparkle	
Headrests	4	
Waterfalls	One with independent flow rate (on or off) adjustment; powered by pump 1	
Heater:	Hi Flow 1.0kW/4kW	
Export (50 Hz):	Hi Flow 3.0kW	
Electrical Requirements:	North America (60 Hz): Convertible 120 VAC@15A Export (50 Hz): 230-240V@1x16A, 1X32A	
Warranty*	North America (60 Hz): 5 Years Shell, 5 Years Shell Surface, 1 Year Plumbing Component Leaks, 1 Year Equipment and Controls, 1 Year Cabinet, 1 Year Jets, 1 Year Lights; Export (50 Hz): 5 Years Shell, 5 Years Shell Surface, 2 Years Plumbing Component Leaks, 2 Years Equipment and Controls, 2 Years Cabinet, 2 Years Jets, 2 Years Lights;	
Special Features	N/A	

*(See Warranty Document for Specific Details)

Dimensions/Specifications are Subject to Change Without Notice

Echo 30 Jets

Operation/Seat Depths

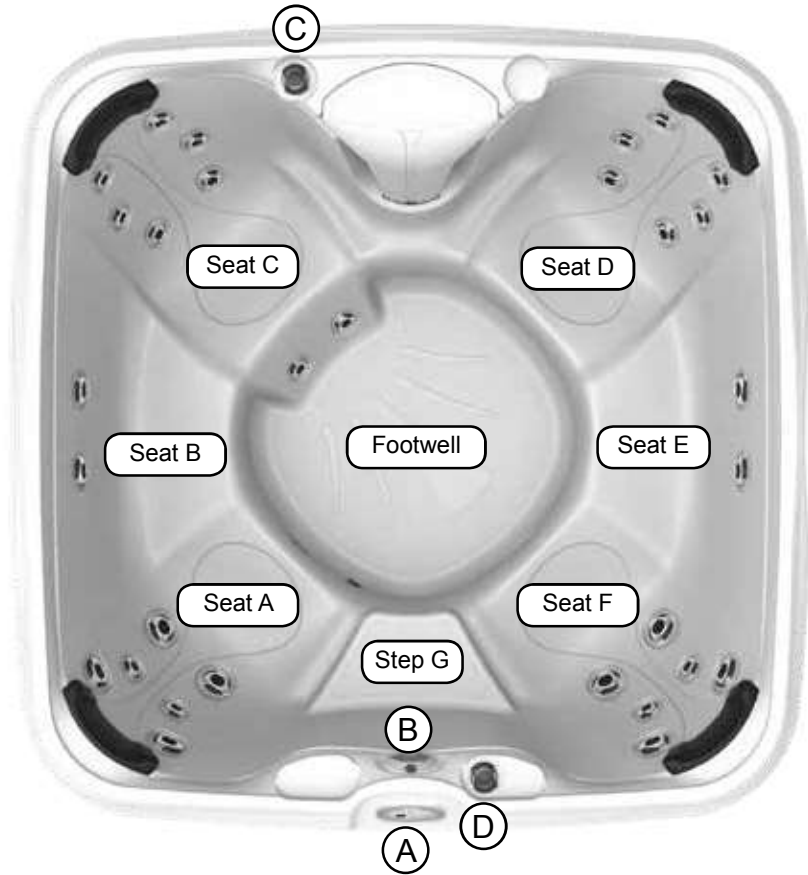

- Ⓐ Topside Control - Activate Jet Pump, Light and Control Water Temperature
 - Ⓑ Water Feature Control - Controls Water Feature Output.
 - Ⓒ Air Control - Activates Seat A Jets (4 DirectionalMax1 Jets, 2 DirectionalMax2 Jets), Seat B Jets (2 DirectionalMax1 Jets), Seat C Jets (8 DirectionalMax2 Jets)
 - Ⓓ Air Control - Activates Seat D Jets (6 DirectionalMax2 Jets), Seat E Jets (2 DirectionalMax1 Jets), Seat F Jets (4 DirectionalMax1 Jets, 2 DirectionalMax2 Jets)
- Jet Pump 1: All seats and footwell jets

30 Total Jets

DirectionalMax1
Jets (12)

DirectionalMax2
Jets (18)



Spa Operation Subject to Change without Notice

- A = 26.50" (67.30 cm)
- B = 24.75" (62.86 cm)
- C = 28.00" (71.12 cm)
- D = 28.00" (71.12 cm)
- E = 24.75" (62.86 cm)
- F = 26.50" (67.30 cm)
- G = 20.00" (50.80 cm)
- H = 34.50" (87.63 cm)

Seat Depths

Listed dimensions represent distance from top of spa to lowest point in seat.
Tolerance: $\pm 0.5"$ (1.27 cm)



Dimensions/Specifications are Subject to Change Without Notice

Echo 30 Jets

Dimensions

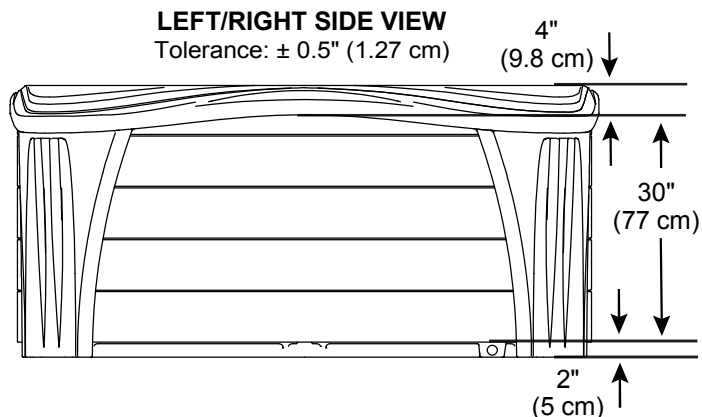
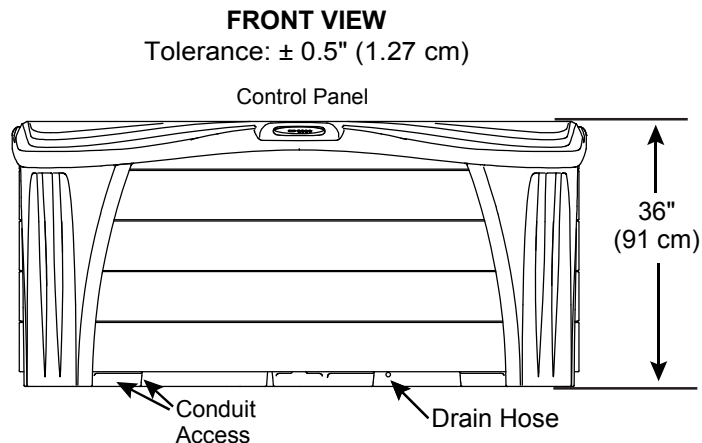
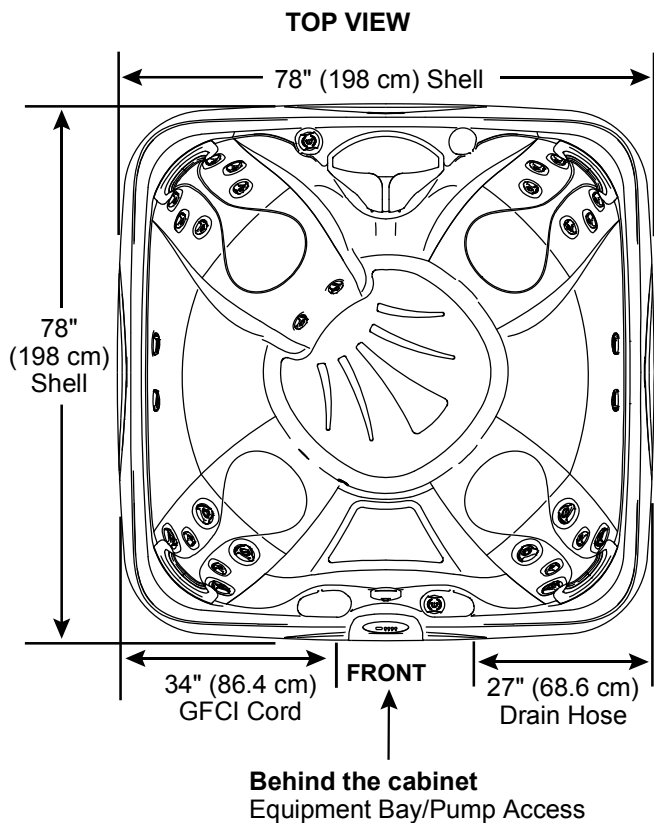

IMPORTANT! Always measure each hot tub for exact dimensions BEFORE designing its foundational support and/or decking.

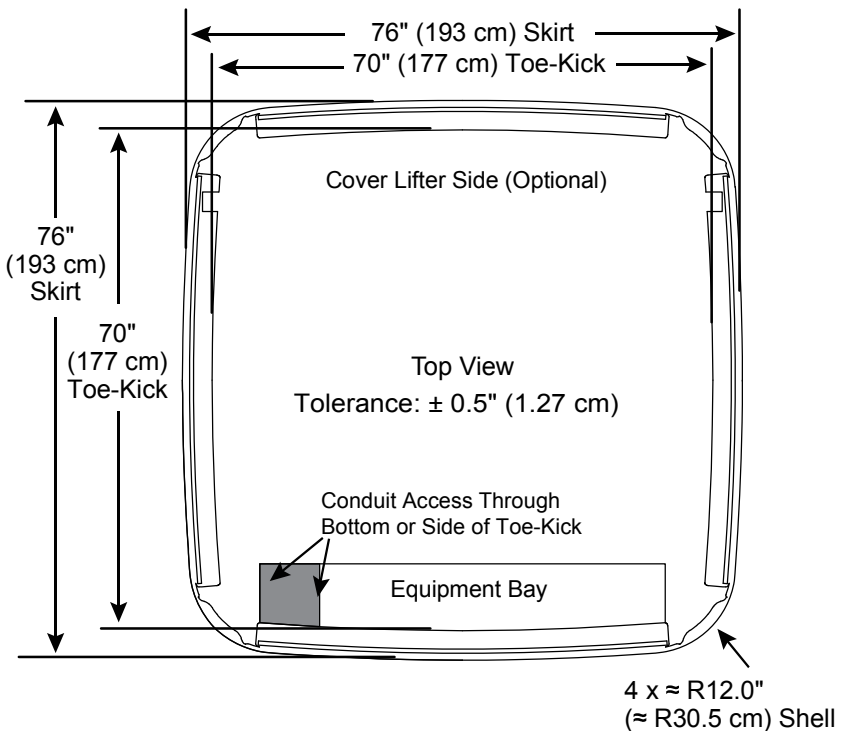

Dimensions/specifications subject to change without notice. Tolerance $\pm 0.5"$ (1.27 cm)

Mood 20™ Jets

Specifications

Seating Capacity	5 Adults
Dimensions	78" x 68" x 32" (198 cm x 173 cm x 81 cm);
Dry Weight	285 lbs (129 kg)
Filled Weight (Spa Volume)	3,120 lbs (1,415 kg)
Filled Weight (Average Fill)	2,404 lbs (1,090 kg)
Water Capacity (Spa Volume) ...	340 US gallons (1,287 Liters)
Water Capacity (Average Fill) ...	254 US gallons (961 Liters)
Electronic Controls	Digital Touch Controller. Offers customizing of cleaning cycles and water temperature setting.
Pump 1	North America (60 Hz): 2-Speed, 2.0 HPR continuous
Export (50 Hz):	2-Speed, 1.5 HP
Pump 2	N/A
Export (50 Hz):	N/A
Circulation Pump	N/A
Total Jets	20
Seat A Jets	1 DirectionalMax1, 1 DirectionalMax2
Seat B Jets	2 DirectionalMax1
Seat C Jets	1 DirectionalMax1, 1 DirectionalMax2
Seat D Jets	2 DirectionalMax1, 2 DirectionalMax2, 2 DirectMiniMax
Seat E Jets	2 DirectionalMax1, 2 DirectionalMax2, 2 DirectMiniMax
Footwell (F) Jets	2 DirectionalMax1
Massage Selectors	N/A
Air Controls	2
Water Management System	One Easy Kleen 30 ft ² filter cartridge; Optional factory installed Ozone
Export (50 Hz):	Optional factory installed Ozone
LED Lighting	Multicolor Waterfall light; Footwell light, Exterior corner lights (8 qty)
Shell/Cabinet Colors	Mystic Sparkle, Tuscan Sparkle, Night Sparkle, Glacier Sparkle
Headrests	2
Waterfalls	One with independent flow rate (on or off) adjustment; powered by pump 1
Heater:	Hi Flow 1.0kW/4kW
Export (50 Hz):	Hi Flow 3.0kW
Electrical Requirements:	North America (60 Hz): Convertible 120 VAC@15A or 240 VAC@30A, 40A Export (50 Hz): 230-240V@1x16A, 1X32A
Warranty*	North America (60 Hz): 5 Years Shell, 5 Years Shell Surface, 1 Year Plumbing Component Leaks, 1 Year Equipment and Controls, 1 Year Cabinet, 1 Year Jets, 1 Year Lights; Export (50 Hz): 5 Years Shell, 5 Years Shell Surface, 2 Years Plumbing Component Leaks, 2 Years Equipment and Controls, 2 Years Cabinet, 2 Years Jets, 2 Years Lights;
Special Features	Optional Suite Package Add-On

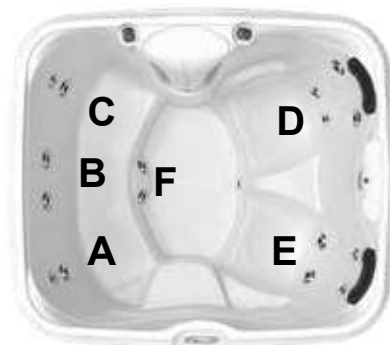

*(See Warranty Document for Specific Details)

Dimensions/Specifications are Subject to Change Without Notice

Mood 20 Jets

Operation/Seat Depths

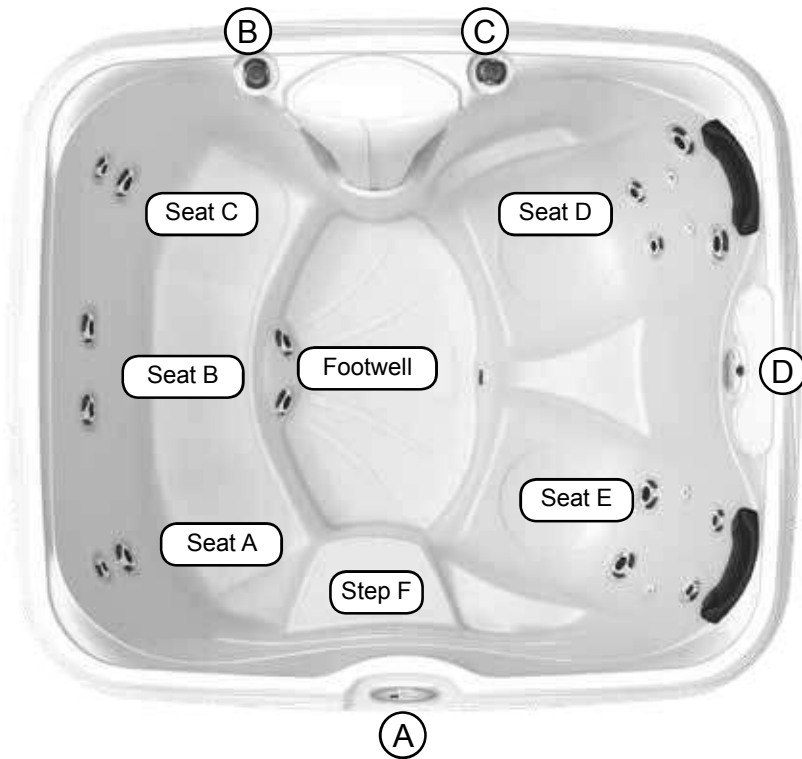

- (A) Topside Control - Activate Jets Pump, Light and Control Water Temperature
- (B) Air Control - Activates Seat A Jets (1 DirectionalMax1 Jet, 1 DirectionalMax2 Jet), Seat B Jets (2 DirectionalMax1 Jets), Seat C Jets (1 DirectionalMax1 Jet, 1 DirectionalMax2 Jet), Footwell Jets (2 DirectionalMax2 Jets)
- (C) Air Control - Activates Seat D Jets (2 DirectionalMax1 Jets, 2 DirectionalMax2 Jets, 2 DirectMiniMax Jets), Seat E Jets (2 DirectionalMax1 Jets, 2 DirectionalMax2 Jets, 2 DirectMiniMax Jets)
- (D) Water Feature Control - Controls Water Feature Output.

- Jet Pump 1: All seats and footwell jets

20 Total Jets

DirectionalMax1
Jets (10)

DirectionalMax2
Jets (6)

DirectMiniMax
Jets (4)



Spa Operation Subject to Change without Notice

- A = 26.50" (67.31 cm)
- B = 26.25" (66.68 cm)
- C = 26.50" (67.31 cm)
- D = 26.25" (66.68 cm)
- E = 28.30" (71.87 cm)
- F = 18.00" (45.72 cm)
- G = 30.50" (77.47 cm)

Seat Depths

Listed dimensions represent distance from top of spa to lowest point in seat.
Tolerance: $\pm 0.5"$ (1.27 cm)



Dimensions/Specifications are Subject to Change Without Notice

Mood 20 Jets

Dimensions

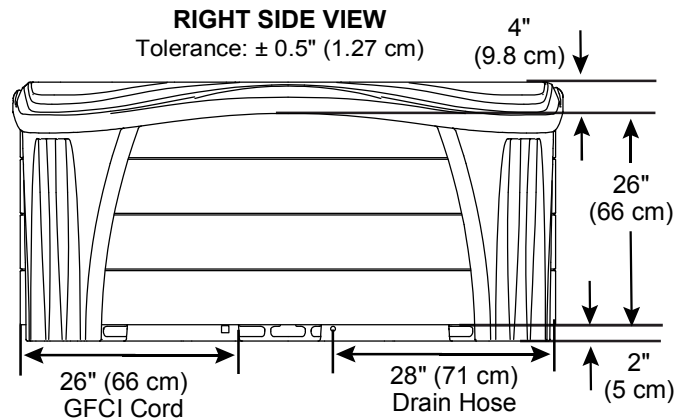
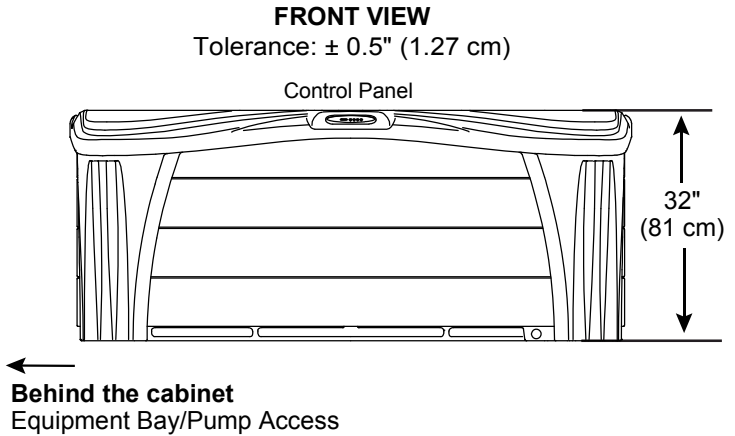
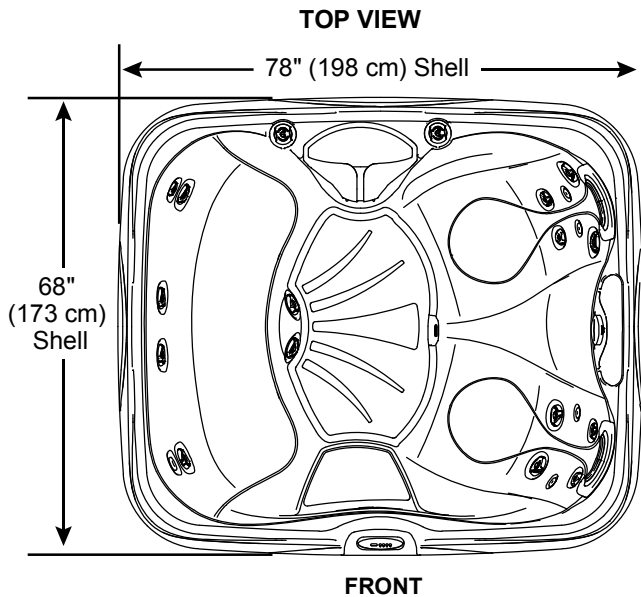

IMPORTANT! Always measure each hot tub for exact dimensions BEFORE designing its foundational support and/or decking.

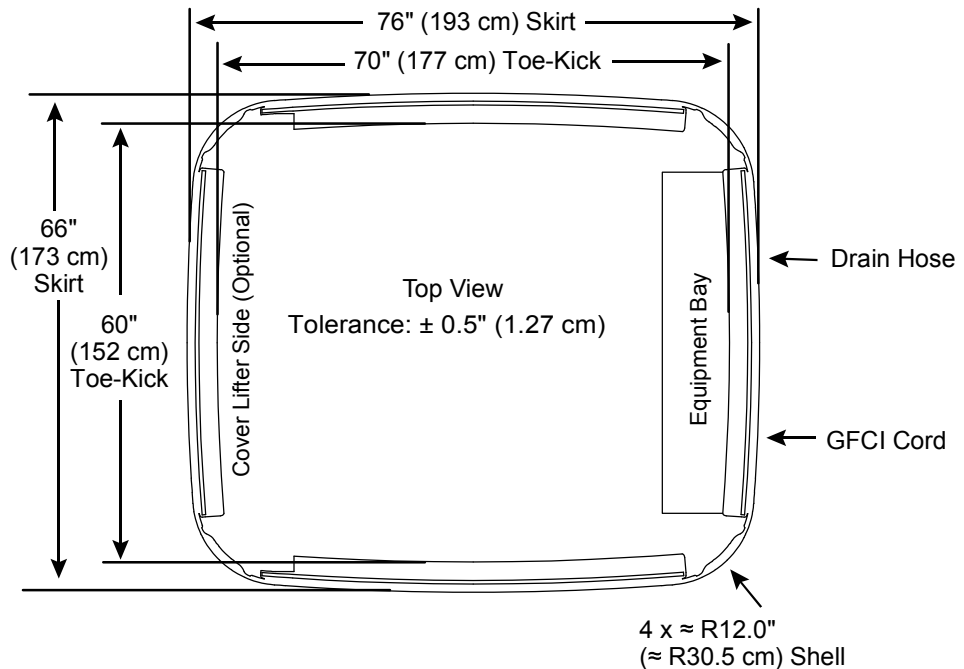

Dimensions/specifications subject to change without notice. Tolerance $\pm 0.5"$ (1.27 cm)